

ENERGYMID|EM

M-Bus Interface of Energy Meters U228X-W2, U238X-W2

3-349-909-03
4/4.19





Table of Contents

1	Overview	3
2	Telegram Formats	3
2.1	Telegram Fields	3
2.1.1	C Field.....	3
2.1.2	A Field.....	4
2.1.3	CI Field.....	4
2.1.4	L Field	4
2.1.5	CS Field	5
2.2	User Data (long telegram).....	5
2.2.1	Coding of User Data from the Slave to the Master: Beginning of the Telegrams	5
2.2.2	Coding of User Data from the Slave to the Master: Data Records.....	5
3	Communications Process	9
3.1	Transmission/Acknowledgement Procedure.....	9
3.1.1	SND_NKE	9
3.1.2	SND_UD	10
3.1.3	REQ_UD2	36
3.1.4	RSP_UD	36
4	Appendix	45
4.1	Communication Procedure.....	45
4.2	Parameter Set List – All Retrievable Values	46
4.3.	Standard Telegram	49
5	Application Notes	50
5.1	Operating Logbook and Counter Reading Profile (feature Z1).....	50
5.2	Cutoff Date Meter.....	50
5.3	Resettable Meter.....	50
5.4.	Set Telegram	51
5.5.	ENERGYMID Tool	52
6	Control and Display Functions	54
7	Product Support	55

1 Overview

- M-Bus interface per EN13757-2 and EN13757-3
- Wired with 2-wire twisted-pair cable
- 2 screw terminals for M-Bus connection
- M-Bus interface current consumption: $\leq 1,5$ mA. This corresponds to 1 standard load.
- Selectable data transmission rates: 300, 600, 1200, **2400**, 4800 or 9600 baud
- The standard baud rate is 2400 baud.
- The standard primary address is 0.

2 Telegram Formats

There are 3 telegram formats, each of which has a different first byte:

- Single character:

This telegram consists of the E5h character only and serves the purpose of receipt acknowledgement.

- Short telegram:

This telegram is distinguished by its start character, namely 10h, and always includes 5 characters. It's used by the M-Bus master to request data from the M-Bus slave.

- Long telegram:

This telegram begins with start character 68h. It consists of a variable number of bytes and also includes data. It's used by the M-Bus master in order to transmit commands to the M-Bus slave, and by the M-Bus slave to transmit requested data to the M-Bus master.

Byte	Single Character	Short Telegram	Long Telegram
1	E5	10	68
2		C field	L field
3		A field	L field (repetition)
4		CS (checksum)	68
5		16	C field
6			A field
7			CI field
8 ... YY			Data (0 ... 246 bytes)
YY + 1			CS (checksum)
YY + 2			16

Table 2.1: M-Bus Telegram Formats (all bytes in hexadecimal format).

2.1 Telegram Fields

Telegram fields C, A, CI, L and CS have a length of 1 byte (8 bits) and execute predefined tasks for M-Bus communication.

2.1.1 C Field

The **control field** contains information about the direction of communication, success of the current transmission and the function of the telegram.

Bit Number	7	6	5	4	3	2	1	0
Master > slave	0	1	FCB	FCV	F3	F2	F1	F0
Slave > master	0	0	ACD	DFC	F3	F2	F1	F0

Table 2.1.1a: C Field Bit Sequence

Bit no. 6 indicates the direction of communication. It's set to 1 in the master to slave direction, and otherwise to 0. When the master sets bit 4 (**FCV = frame count bit valid**) to 1 the slave must observe bit 5 (**FCB = frame count bit**), and the slave should otherwise ignore the FCB. The FCB indicates that successful transmission has taken place. The master switches the bit after receiving a successful response from a slave. In the case of a multiple telegram, the slave must then send the next telegram of the response. If the expected response is not transmitted or if receipt of the response fails, the master sends the same telegram with unchanged FCB once again.

Bits 3 to 0 represent the function code of the message. The most important variants are as follows:

Telegram Name	C Field (bin)	C Field (hex)	Telegram Type	Description
SND_NKE	01000000	40	Short	Initialization of the slave
SND_UD	01x10011	53 / 73	Long	Master sends data to slave
REQ_UD2	01x11011	5B / 7B	Short	Master requests class 2 data
RSP_UD	000x1000	08 / 18	Long	Data transfer from slave to master

Table 2.1.1b: C Field Coding of the Commands Utilized Here

2.1.2 A Field

The **address field** is used to address the recipient and to identify the sender in the response direction. The field with a size of 1 byte can take on values within a range of 0 to 255 as described below:

A Field (hex)	Primary Address	Comments
00	0	Default setting
01 ... FA	1 ... 250	Valid primary address
FB, FC	251, 252	Reserved for future applications
FD	253	Addressing via secondary address
FE	254	Transmission to all M-Bus participants with response
FF	255	Transmission to all M-Bus participants without response

Table 2.1.2: Address Field Values

Addresses 254 and 255 are for broadcasts, i.e. messages sent simultaneously to all M-Bus participants. When address 254 (FEh) is used, each slave responds with an acknowledgment (E5h) or its primary address. This may cause collisions. In contrast, none of the slaves responds in the case of address 255 (FFh).

2.1.3 CI Field

The **control information field** contains information for the telegram recipient. The following values are used:

CI Field (hex)	Primary Address
51	The telegram contains data for the slave.
52	Selection of a slave
72	The telegram contains data for the master.
B8	Selected baud rate of 300 bps
B9	Selected baud rate of 600 bps
BA	Selected baud rate of 1200 bps
BB	Selected baud rate of 2400 bps
BC	Selected baud rate of 4800 bps
BD	Selected baud rate of 9600 bps

Table 2.1.3: Control Information Field Values

2.1.4 L Field

The **length field** contains the number of user data included in the telegram expressed in terms of bytes, plus 3 bytes for the C, A and CI fields.

This field is always transmitted two times, one after the other, within the long telegram.

2.1.5 CS Field

The **checksum field** is used to detect transmission and synchronization errors and is generated from the arithmetic sum of the C and A fields, as well as the CI field if applicable, and the user data, i.e. from the C field to the CS field (except CS).

2.2 User Data (long telegram)

The user data (0 ... 246 bytes) in the long telegram contains the data queried from the slave (read-out data), or command information transmitted from the master to the slave.

2.2.1 Coding of User Data from the Slave to the Master: Beginning of the Telegrams

Each block of user data from the slave begins with the following **fixed data record header (FDH)**:

Byte No.	Size (bytes)	Value (hex)	Description
1 ... 4	4	xx xx xx xx	Identification number of the M-Bus participant
5 ... 6	2	xx xx	Manufacturer's ID
7	1	xx	Version number of the M-Bus interface firmware (00 ... FF)
8	1	02	Medium: electrical quantities (electricity)
9	1	xx	Telegram counter (00 ... FF)
10	1	00 01	M-Bus interface status (00 = meter not addressable, 01 = meter addressable)
11 ... 12	2	0000	Signature (always 0000, i.e. not used)

Table 2.2.1: Fixed Data Record Header

The identification number is an 8 digit number which can be changed by the user (00000000 to 99999999). The telegram counter has no preceding plus or minus sign and is increased by one after each RSP_UD from the slave (modulo 256).

2.2.2 Coding of User Data from the Slave to the Master: Data Records

Each data record sent from a slave to the master includes the following **data record header (DRH)**:

Data Record Header				Data
Data Information Block (DIB)		Value Information Block (VIB)		
DIF	DIFE	VIF	VIFE	
1 byte	0 ... 10 bytes	1 byte	0 ... 10 bytes	

Table 2.2.2: Data Records Structure

2.2.2.1 Data Information Block (DIB)

The data information block (DIB) includes at least one data information field (DIF). This DIF byte can be expanded with a data information field extension (DIFE) of up to 10 bytes.

DIF coding for this protocol:

Bit	Name	Description
7	Extension bit	Indicates whether or not a DIFE byte follows: 0 = no 1 = yes
6	LSB of the memory location number	Always 0, i.e. not used
5 ... 4	Function field	Specifies the type of value, always: 00 = momentary value
3 ... 0	Data field	Length and coding of the data: 0001: 8-bit integer 0010: 16-bit integer 0011: 24-bit integer 0100: 32-bit integer 0110: 48-bit integer 0111: 64-bit integer 1100: 8-digit BCD 1101: variable length

Table 2.2.2.1: Data Information Field Structure (DIF)

Coding of the first DIFE for power and energy:

Bit	Name	Description
7	Extension bit	Indicates whether or not a further DIFE byte follows: 1 = yes
6	Unit	Specifies the type of energy or power: 0 = active 1 = reactive
5 ... 4	Tariff	Specifies the tariff to which the values belong: Bit 5 ... tariff bit 1 Bit 4 ... tariff bit 0
3 ... 0	Memory location number	Always 0000

Table 2.2.2.1a

Coding of the second DIFE for power and energy:

Bit	Name	Description
7	Extension bit	Indicates whether or not a further DIFE byte follows: 0 = no (for power) 1 = yes (for energy)
6	Unit	Specifies the source of energy or power: 0 = primary 1 = secondary
5 ... 4	Tariff	Specifies the tariff to which the values belong: Bit 5 ... tariff bit 3 Bit 4 ... tariff bit 2
3 ... 0	Memory location number	Always 0000

Table 2.2.2.1b

Coding of the third DIFE for power and energy:

Bit	Name	Description
7	Extension bit	Indicates whether or not a DIFE byte follows: 0 = no
6	Unit	Specifies the type of energy: 0 = imported 1 = exported
5 ... 4	Tariff	Bit 5 ... always 0 Bit 4 ... always 0
3 ... 0	Memory location number	Always 0000

Table 2.2.2.1c

2.2.2.2 Value Information Block

The value information block (**VIB**) includes at least one value information field (**VIF**). This byte can be expanded with a value information field extension (**VIFE**) of up to 10 values.

VIF coding:

Bit	Name	Description
7	Extension bit	Indicates whether or not a VIFE byte follows: 0 = no 1 = yes
6 ... 0	Value information	Includes information about the individual value such as unit, multiplier etc.

Table 2.2.2.2a: Value Information Field Structure (VIF)

VIFE coding:

Bit	Name	Description
7	Extension bit	Indicates whether or not a further VIFE byte follows: 0 = no 1 = yes
6 ... 0	Value information	Includes information about the individual value such as unit, multiplier etc.

Table 2.2.2.2a: Value Information Field Extension Structure (VIFE)

2.2.2.3 Standard Value Information Field (VIF)

VIFE (bin)	VIFE (hex)	Description	Unit
00100010	22	Total operating hours	h
01111001	79	Setting of the secondary address	None
01111010	7A	Setting of the primary address	None
10000010	8x	Energy	See section 3.1.4.9
10101000	A8	Power	W
11111101	FD	A standard VIFE from table extension follows	None
11111111	FF	Further manufacturer-specific VIFE follows	None

Table 2.2.2.3: Standard Value Information Field

2.2.2.4 Standard Value Information Field Extension (VIFE)

VIF (bin)	VIF (hex)	Description	Unit
00001011	0B	Parameter mask identification	None
00001100	0C	Firmware version	None
00001101	0D	Hardware version	None
11001100	CC	Voltage	V
11011001	D9	Current	A

Table 2.2.2.4: Standard Value Information Field Extension

2.2.2.5 Manufacturer-Specific VIFE

VIFE (hex)	Description
00	Mean value of the phases
01	Phase 1
02	Phase 2
03	Phase 3
04	Neutral
05	Phase 1 to phase 2
06	Phase 2 to phase 3
07	Phase 3 to phase 1
08	Mean value, phase-to-phase
09	Total
0A	Resettable
0B	Cutoff date function
10	THD voltage (steps of 0.001)
11	THD current (steps of 0.001)
12	Frequency (unit: mHz)
13	Power factor (steps of 0.001)
14	Momentary tariff
15	Current transformer ratio (CT)
16	Voltage transformer ratio (VT)
17	Read operating logbook data
18	Read load profile data
19	Specified date point for next reset
1A	Load profile integrating period
1B	Meter features
1C	Next specified cutoff date
1D	Date on which resettable meter readings were last reset
1E	Last cutoff date
20	Operating hours since last reset
21	Clear data memory
22	Version
23	Define tariff

Table 2.2.2.5: Manufacturer-Specific Information Field Extensions

If bit 7 in the specific value information field extension (VIFE) is set to 1, a further VIFE byte follows. If bit 7 is set to 0, the first data byte follows directly.

3 Communications Process

The M-Bus interface accepts two types of transmission:

Send / confirm > SND / CON
Request / respond > REQ / RSP

Standard communication between M-Bus master and M-Bus slave is as follows:

 Master > Slave
 SND_NKE > E5h
 SND_UD > E5h
 REQ_UD2 > RSP_UD

3.1 Transmission/Acknowledgement Procedure

3.1.1 SND_NKE

The procedure is used for starting after an interruption or after beginning communication. If the slave has been selected for secondary addressing, it's unselected.

The value of the frame count bit (FCB) in the slave is reset, i.e. it's expected that the first telegram from a master with (FCV = 1) includes (FCB = 1).

The slave acknowledges correct receipt of a telegram with the single character acknowledgement (E5h), or doesn't respond if the telegram has not been correctly received.

Structure of the SND_NKE command:

Byte No.	Size (bytes)	Value (hex)	Description
1	1	10	Start character – short telegram
2	1	40	C field
3	1	Xx	A field – primary address 00 ... FA: valid primary address FB, FC: reserved for future applications FD: addressing via secondary address FE: transmission to all M-Bus slaves (each slave responds with E5h) FE: transmission to all M-Bus slaves (no slaves respond)
4	1	Xx	CS (checksum), calculated from bytes 2 and 3
5	1	16	End-of-message character

Table 3.1.1: SND_NKE Command Structure

Response from the slave: E5h

3.1.2 SND_UD

This procedure is used to transmit user data to the M-Bus slave. The slave acknowledges correct receipt of the telegram with the single character acknowledgement (E5h), or doesn't respond if the telegram has not been correctly received.

The structure of the SND_UD used in this protocol is described in the following subsections.

3.1.2.1 Setting the Primary Address

This functions makes it possible to set a new primary address at the slave.

Command for changing when using the slave's primary address:

Byte No.	Size (bytes)	Value (hex)	Description
1	1	68	Start character (long telegram)
2	1	06	L field
3	1	06	L field (repetition)
4	1	68	Start character (long telegram, repetition)
5	1	73	C field, SND_UD
6	1	xx	A field, primary address (00 ... FF = 0 ... 255)
7	1	51	CI field
8	1	01	DIF: 8-bit integer, 1 byte
9	1	7A	VIF: set primary address
10	1	xx	Value: new primary address Valid range: 00 ... FA (0 ... 250), invalid range: FB ... FF
11	1	xx	CS (checksum)
12	1	16	End-of-message character

Table 3.1.2.1a: SND_UD Command – Setting the Primary Address with the Help of the Primary Address

Command for changing when using the slave's secondary address:

Byte No.	Size (bytes)	Value (hex)	Description
1	1	68	Start character (long telegram)
2	1	0E	L field
3	1	0E	L field (repetition)
4	1	68	Start character (long telegram, repetition)
5	1	73	C field, SND_UD
6	1	FD	A field, primary address = 253, i.e. addressing via the secondary address
7	1	51	CI field
8 ... 15	8	xx xx xx xx xx xx xx xx	Secondary address
16	1	01	DIF: 8-bit integer, 1 byte
17	1	7A	VIF: set primary address
18	1	xx	Value: new primary address Valid range: 00 ... FA (0 ... 250), invalid range: FB ... FF (251 ... 255)
19	1	xx	CS (checksum)
20	1	16	End-of-message character

Table 3.1.2.1b: SND_UD Command – Setting the Primary Address with the Help of the Secondary Address

Response from the slave: E5h

3.1.2.2 Setting the Secondary Address

This functions makes it possible to set a new secondary address at the slave.

The secondary address has the following structure:

Byte No.	Size (bytes)	Value (hex)	Description
1 ... 4	4	xx xx xx xx	Identification number, range: 00000000 ... 99999999
5 ... 6	2	xx xx	Manufacturer ID, range: 01 ... FF, 01 ... FF
7	1	xx	Version number, range: 01 ... FF
8	1	02	Device type identification, 02: electricity

Table 3.1.2.2a: Structure of the Secondary Address

Command for changing when using the slave's primary address:

Byte No.	Size (bytes)	Value (hex)	Description
1	1	68	Start character (long telegram)
2	1	09	L field
3	1	09	L field (repetition)
4	1	68	Start character (long telegram, repetition)
5	1	73	C field, SND_UD
6	1	xx	A field, primary address (00 ... FF = 0 ... 255)
7	1	51	CI field
8	1	0C	DIF: 8-digit BCD, 4-byte
9	1	79	VIF: set secondary address
10	1	xx	Value: new secondary address digits 7 and 8 Range: 00 ... 99
11	1	xx	Value: new secondary address digits 5 and 6 Range: 00 ... 99
12	1	xx	Value: new secondary address digits 3 and 4 Range: 00 ... 99
13	1	xx	Value: new secondary address digits 1 and 2 Range: 00 ... 99
14	1	xx	CS (checksum)
15	1	16	End-of-message character

Table 3.1.2.2b: SND_UD command – Setting the Secondary Address with the Help of the Primary Address

Command for changing when using the slave's secondary address:

Byte No.	Size (bytes)	Value (hex)	Description
1	1	68	Start character (long telegram)
2	1	11	L field
3	1	11	L field (repetition)
4	1	68	Start character (long telegram, repetition)
5	1	73	C field, SND_UD
6	1	FD	A field, primary address = 253, i.e. addressing via the secondary address
7	1	51	CI field
8 ... 15	8	xx xx xx xx xx xx xx xx	Secondary address
16	1	0C	DIF: 8-digit BCD, 4-byte
17	1	79	VIF: set secondary address
18	1	xx	Value: new secondary address digits 7 and 8 Range: 00 ... 99
19	1	xx	Value: new secondary address digits 5 and 6 Range: 00 ... 99
20	1	xx	Value: new secondary address digits 3 and 4 Range: 00 ... 99
21	1	xx	Value: new secondary address digits 1 and 2 Range: 00 ... 99
22	1	xx	CS (checksum)
23	1	16	End-of-message character

Table 3.1.2.2c: SND_UD command – Setting the Secondary Address with the Help of the Secondary Address

Response from the slave: E5h

3.1.2.3 Setting the Baud Rate

This function makes it possible to change the baud rate of the M-Bus slave.

The slave responds with the single character acknowledgement (E5h) with the old baud rate. As soon as the acknowledgement has been sent, the slave is switched to the new baud rate.

In order to assure that the slave has changed its baud rate correctly, the master must send a telegram to the slave with the new baud rate within 2 minutes. If the slave does not send an ACK after x attempts, the master must return to the old baud rate.

Command when using the slave's primary address:

Byte No.	Size (bytes)	Value (hex)	Description
1	1	68	Start character (long telegram)
2	1	03	L field
3	1	03	L field (repetition)
4	1	68	Start character (long telegram, repetition)
5	1	73	C field, SND_UD
6	1	xx	A field, primary address (00 ... FA = 0 ... 250 or 253, if selected)
7	1	xx	CI field: set new baud rate B8: set baud rate to 300 baud B9: set baud rate to 600 baud BA: set baud rate to 1200 baud BB: set baud rate to 2400 baud BC: set baud rate to 4800 baud BD: set baud rate to 9600 baud
8	1	xx	CS (checksum)
9	1	16	End-of-message character

Table 3.1.2.3a: SND_UD Command – Setting the Baud Rate with the Help of the Primary Address

Command for changing when using the slave's secondary address:

Byte No.	Size (bytes)	Value (hex)	Description
1	1	68	Start character (long telegram)
2	1	0B	L field
3	1	0B	L field (repetition)
4	1	68	Start character (long telegram, repetition)
5	1	73	C field, SND_UD
6	1	FD	A field, primary address = 253, i.e. addressing via the secondary address
7	1	xx	CI field: set new baud rate B8: set baud rate to 300 baud B9: set baud rate to 600 baud BA: set baud rate to 1200 baud BB: set baud rate to 2400 baud BC: set baud rate to 4800 baud BD: set baud rate to 9600 baud
8 ... 15	8	xx xx xx xx xx xx xx xx	Secondary address
16	1	xx	CS (checksum)
17	1	16	End-of-message character

Table 3.1.2.3a: SND_UD Command – Setting the Baud Rate with the Help of the Secondary Address

Response from the slave: E5h

3.1.2.4 Setting the Active Tariff

This function makes it possible to change the **active tariff**.

Command when using the slave's primary address:

Byte No.	Size (bytes)	Value (hex)	Description
1	1	68	Start character (long telegram)
2	1	07	L field
3	1	07	L field (repetition)
4	1	68	Start character (long telegram, repetition)
5	1	73	C field, SND_UD
6	1	xx	A field, primary address (00 ... FA = 0 ... 250 or 253, if selected)
7	1	51	CI field
8	1	01	DIF: 8-bit integer, 1 byte
9	1	FF	VIF followed by manufacturer-specific VIFE
10	1	23	Manufacturer-specific VIFE: define tariff
11	1	xx	Value: 00: tariff selection via hardware tariff input (default), see also operating instructions 01 ... 08: tariff controlled via bus
12	1	xx	CS (checksum)
13	1	16	End-of-message character

Table 3.1.2.4a

Command when using the slave's secondary address:

Byte No.	Size (bytes)	Value (hex)	Description
1	1	68	Start character (long telegram)
2	1	0F	L field
3	1	0F	L field (repetition)
4	1	68	Start character (long telegram, repetition)
5	1	73	C field, SND_UD
6	1	FD	A field, primary address = 253, i.e. addressing via the secondary address
7	1	51	CI field
8 ... 15	8	xx xx xx xx xx xx xx xx	Secondary address
16	1	01	DIF: 8-bit integer, 1 byte
17	1	FF	VIF followed by manufacturer-specific VIFE
18	1	23	Manufacturer-specific VIFE: define tariff
19	1	xx	Value: 00: tariff selection via hardware tariff input (default), see also operating instructions 01 ... 08: tariff controlled via bus
20	1	xx	CS (checksum)
21	1	16	End-of-message character

Table 3.1.2.4b

Response from the slave: E5h

Important notes regarding tariff switching via the interface:

- Switching the tariff via the interface is not included in the scope of MID approval.
- However, in order to initially specify the tariff via the interface (value: 1 - 8) after previous hardware control (previous value: 0), the enable key on the device must first be pressed and the key must not appear at the device display. The setting is otherwise ignored! (If this is the case, switching back to 0 is required, after which the enable key must be pressed and the telegram must be sent again.)
- As long as the tariff is specified via the interface (value: 1 - 8), the tariff can always be changed with this telegram. In this state, the tariff can only be specified via the interface.
- Value 0 can be used to switch back to hardware control.
- The currently selected tariff for energy metering is transmitted, for example, with the standard telegram, and it can be read out with the Set Bit 16 parameter (see section “

- 4.2 Parameter Set List – All Retrievable Values”). It appears continuously at the meter’s display as well.
- The tariff specified previously via the interface (this telegram) can be read out with the Set Bit 77 parameter: if a 0 is read (default), the tariff is controlled via the hardware inputs at the meter.

3.1.2.5 Setting Date and Time

This function makes it possible to change date and time.

Command when using the slave's primary address:

Byte No.	Size (bytes)	Value (hex)	Description
1	1	68	Start character (long telegram)
2	1	0B	L field
3	1	0B	L field (repetition)
4	1	68	Start character (long telegram, repetition)
5	1	73	C field, SND_UD
6	1	xx	A field, primary address (00 ... FA = 0 ... 250 or 253, if selected)
7	1	51	CI field
8	1	06	DIF: 48-bit, data field = 0110b, type I
9	1	6D	VIF: extended date and point in time
10 ... 15	1	xx xx xx xx xx xx	Value: type I: date and time (CP48) (see table 3.1.4.10a)
16	1	xx	CS (checksum)
17	1	16	End-of-message character

Table 3.1.2.5a

Command when using the slave's secondary address:

Byte No.	Size (bytes)	Value (hex)	Description
1	1	68	Start character (long telegram)
2	1	13	L field
3	1	13	L field (repetition)
4	1	68	Start character (long telegram, repetition)
5	1	73	C field, SND_UD
6	1	FD	A field, primary address = 253, i.e. addressing via the secondary address
7	1	51	CI field
8 ... 15	8	xx xx xx xx xx xx xx xx	Secondary address
16	1	06	DIF: 48-bit, data field = 0110b, type I
17	1	6D	VIF: extended date and point in time
18 ... 23	1	xx xx xx xx xx xx	Value: type I: date and time (CP48) (see table 3.1.4.10a)
24	1	xx	CS (checksum)
25	1	16	End-of-message character

Table 3.1.2.5b

Response from the slave: E5h

3.1.2.6 Setting the Current Transformer's Transformation Ratio (CT)

This function makes it possible to change the current transformer's transformation ratio (CT). This change is only supported by accordingly adjustable meters (feature Q1).

Command when using the slave's primary address:

Byte No.	Size (bytes)	Value (hex)	Description
1	1	68	Start character (long telegram)
2	1	08	L field
3	1	08	L field (repetition)
4	1	68	Start character (long telegram, repetition)
5	1	73	C field, SND_UD
6	1	xx	A field, primary address (00 ... FA = 0 ... 250 or 253, if selected)
7	1	51	CI field
8	1	02	DIF: 16-bit integer, 2-byte
9	1	FF	VIF followed by manufacturer-specific VIFE
10	1	15	Manufacturer-specific VIFE: CT value
11 ... 12	1	xx xx	New CT value
13	1	xx	CS (checksum)
14	1	16	End-of-message character

Table 3.1.2.6a

Command when using the slave's secondary address:

Byte No.	Size (bytes)	Value (hex)	Description
1	1	68	Start character (long telegram)
2	1	10	L field
3	1	10	L field (repetition)
4	1	68	Start character (long telegram, repetition)
5	1	73	C field, SND_UD
6	1	FD	A field, primary address = 253, i.e. addressing via the secondary address
7	1	51	CI field
8 ... 15	8	xx xx xx xx xx xx xx xx	Secondary address
16	1	02	DIF: 16-bit integer, 2-byte
17	1	FF	VIF followed by manufacturer-specific VIFE
18	1	15	Manufacturer-specific VIFE: CT value
19 ... 20	1	xx xx	New CT value
21	1	xx	CS (checksum)
22	1	16	End-of-message character

Table 3.1.2.6b

Response from the slave: E5h

3.1.2.7 Setting the Voltage Transformer's Transformation Ratio

This function makes it possible to change the voltage transformer's transformation ratio (VT). This change is only supported by accordingly adjustable meters (feature Q1).

Command when using the slave's primary address:

Byte No.	Size (bytes)	Value (hex)	Description
1	1	68	Start character (long telegram)
2	1	08	L field
3	1	08	L field (repetition)
4	1	68	Start character (long telegram, repetition)
5	1	73	C field, SND_UD
6	1	xx	A field, primary address (00 ... FA = 0 ... 250 or 253, if selected)
7	1	51	CI field
8	1	02	DIF: 16-bit integer, 2-byte
9	1	FF	VIF followed by manufacturer-specific VIFE
10	1	16	Manufacturer-specific VIFE: VT value
11 ... 12	1	xx xx	New VT value
13	1	xx	CS (checksum)
14	1	16	End-of-message character

Table 3.1.2.7a

Command when using the slave's secondary address:

Byte No.	Size (bytes)	Value (hex)	Description
1	1	68	Start character (long telegram)
2	1	10	L field
3	1	10	L field (repetition)
4	1	68	Start character (long telegram, repetition)
5	1	73	C field, SND_UD
6	1	FD	A field, primary address = 253, i.e. addressing via the secondary address
7	1	51	CI field
8 ... 15	8	xx xx xx xx xx xx xx xx	Secondary address
16	1	02	DIF: 16-bit integer, 2-byte
17	1	FF	VIF followed by manufacturer-specific VIFE
18	1	16	Manufacturer-specific VIFE: VT value
19 ... 20	1	xx xx	New VT value
21	1	xx	CS (checksum)
22	1	16	End-of-message character

Table 3.1.2.7b

Response from the slave: E5h

3.1.2.8 Reading Out the Operating Logbook

This function makes it possible to read out the operating logbook from flash memory.

Command when using the slave's primary address:

Byte No.	Size (bytes)	Value (hex)	Description
1	1	68	Start character (long telegram)
2	1	07	L field
3	1	07	L field (repetition)
4	1	68	Start character (long telegram, repetition)
5	1	73	C field, SND_UD
6	1	xx	A field, primary address (00 ... FA = 0 ... 250 or 253, if selected)
7	1	51	CI field
8	1	01	DIF: 8-bit integer, 1 byte
9	1	FF	VIF followed by manufacturer-specific VIFE
10	1	17	Manufacturer-specific VIFE: read operating logbook
11	1	xx	Query detail: 00: the latest entry 01: the previous entry 02: the next entry
12	1	xx	CS (checksum)
13	1	16	End-of-message character

Table 3.1.2.8a

Response from the slave:

Byte No.	Size (bytes)	Value (hex)	Description
1	1	68	Start character (long telegram)
2	1	27	L field
3	1	27	L field (repetition)
4	1	68	Start character (long telegram, repetition)
5	1	08	C field RSP_UD
6	1	xx	A field, primary address (00 ... FA = 0 ... 250)
7	1	72	CI field
8	1	0D	DIF: variable length
9	1	FF	VIF followed by manufacturer-specific VIFE
10	1	17	Manufacturer-specific VIFE: read operating logbook
11	1	20	LVAR = 32d
12 ... 43	32	xx-xx	Operating logbook data
44	1	xx	CS (checksum)
45	1	16	End-of-message character

Table 3.1.2.8b

Command when using the slave's secondary address:

Byte No.	Size (bytes)	Value (hex)	Description
1	1	68	Start character (long telegram)
2	1	0F	L field
3	1	0F	L field (repetition)
4	1	68	Start character (long telegram, repetition)
5	1	73	C field, SND_UD
6	1	FD	A field, primary address = 253, i.e. addressing via the secondary address
7	1	51	CI field
8 ... 15	8	xx xx xx xx xx xx xx xx	Secondary address
16	1	01	DIF: 8-bit integer, 1 byte
17	1	FF	VIF followed by manufacturer-specific VIFE
18	1	17	Manufacturer-specific VIFE: read operating logbook
19	1	xx	Query detail: 00: the latest entry 01: the previous entry 02: the next entry
20	1	xx	CS (checksum)
21	1	16	End-of-message character

Table 3.1.2.8c

Response from the slave:

Byte No.	Size (bytes)	Value (hex)	Description
1	1	68	Start character (long telegram)
2	1	2F	L field
3	1	2F	L field (repetition)
4	1	68	Start character (long telegram, repetition)
5	1	08	C field RSP_UD
6	1	xx	A field, primary address (00 ... FA = 0 ... 250)
7	1	72	CI field
8 ... 15	8	xx xx xx xx xx xx xx xx	Secondary address
16	1	0D	DIF: variable length
17	1	FF	VIF followed by manufacturer-specific VIFE
18	1	17	Manufacturer-specific VIFE: read logger data
19	1	20	LVAR = 32d
20 ... 51	32	xx-xx	Logger data structure
52	1	xx	CS (checksum)
53	1	16	End-of-message character

Table 3.1.2.8d

Logger Data Structure Definition

Byte Index	Variable	Format
0	Record index	UINT16
2	Event code	UINT8
3	Parameter (1)	UINT8
4	Parameter (2)	UINT8
5	Parameter (3)	UINT8
6	Parameter (4)	UINT8
7	Parameter (5)	UINT8
8	Parameter (6)	UINT8
9	Parameter (7)	UINT8
10	Operating hours	UINT32
14	Event time	RTC
22 ... 31	Reserve	-----

Table 3.1.2.8e

Event Code Beginning	Event Code End	Description	Parameter
00h		Status OK	
01h	81h	Current too high	Phase number (par 1)
02h	82h	Voltage too high	Phase number (par 1)
03h	83h	No frequency synchronization	
04h	84h	Frequency too low	
05h	85h	Frequency too high	
06h	86h	Incorrect phase sequence	
07h	87h	Unknown phase sequence	
08h	88h	Device is not calibrated	
09h	89h	Phase voltage too low	Phase number (par 1)
0Ah	8Ah	Analog error	
0Bh	8Bh	Energy error	
0Ch	8Ch	Internal communication error	
40h		Date/time changed	New date/time saved (format 8 in par 1 ... 7)
48h		CT changed	New CT value saved (par 1)
49h		VT changed	New VT value saved (par 1)
60h		Reset has occurred without saving date and time	
61h		Mains failure has occurred	

Table 3.1.2.8f

3.1.2.9 Reading Out Counter reading profile Data (with feature Z1 only)

This function makes it possible to read out **counter reading profile data** from the device's internal memory.

Command when using the slave's primary address:

Byte No.	Size (bytes)	Value (hex)	Description
1	1	68	Start character (long telegram)
2	1	07	L field
3	1	07	L field (repetition)
4	1	68	Start character (long telegram, repetition)
5	1	73	C field, SND_UD
6	1	xx	A field, primary address (00 ... FA = 0 ... 250 or 253, if selected)
7	1	51	CI field
8	1	01	DIF: 8-bit integer, 1 byte
9	1	FF	VIF followed by manufacturer-specific VIFE
10	1	18	Manufacturer-specific VIFE: read counter reading profile data
11	1	xx	Query detail: 00: the latest entry 01: the previous entry 02: the next entry
12	1	xx	CS (checksum)
13	1	16	End-of-message character

Table 3.1.2.9a

Response from the slave:

Byte No.	Size (bytes)	Value (hex)	Description
1	1	68	Start character (long telegram)
2	1	47	L field
3	1	47	L field (repetition)
4	1	68	Start character (long telegram, repetition)
5	1	08	C field RSP_UD
6	1	xx	A field, primary address (00 ... FA = 0 ... 250)
7	1	72	CI field
8	1	0D	DIF: variable length
9	1	FF	VIF followed by manufacturer-specific VIFE
10	1	18	Manufacturer-specific VIFE: read counter reading profile data
11	1	40	LVAR = 64d
12 ... 75	64	xx-xx	Load profile data
76	1	xx	CS (checksum)
77	1	16	End-of-message character

Table 3.1.2.9b

Command when using the slave's secondary address:

Byte No.	Size (bytes)	Value (hex)	Description
1	1	68	Start character (long telegram)
2	1	0F	L field
3	1	0F	L field (repetition)
4	1	68	Start character (long telegram, repetition)
5	1	73	C field, SND_UD
6	1	FD	A field, primary address = 253, i.e. addressing via the secondary address
7	1	51	CI field
8 ... 15	8	xx xx xx xx xx xx xx xx	Secondary address
16	1	01	DIF: 8-bit integer, 1 byte
17	1	FF	VIF followed by manufacturer-specific VIFE
18	1	18	Manufacturer-specific VIFE: read counter reading profile data
19	1	xx	Query detail: 00: the latest entry 01: the previous entry 02: the next entry
20	1	xx	CS (checksum)
21	1	16	End-of-message character

Table 3.1.2.9c

Response from the slave:

Byte No.	Size (bytes)	Value (hex)	Description
1	1	68	Start character (long telegram)
2	1	4F	L field
3	1	4F	L field (repetition)
4	1	68	Start character (long telegram, repetition)
5	1	08	C field RSP_UD
6	1	xx	A field, primary address (00 ... FA = 0 ... 250)
7	1	72	CI field
8 ... 15	8	xx xx xx xx xx xx xx	Secondary address
16	1	0D	DIF: variable length
17	1	FF	VIF followed by manufacturer-specific VIFE
18	1	18	Manufacturer-specific VIFE: read counter reading profile data
19	1	40	LVAR = 64d
20 ... 83	64	xx-xx	Load profile data
84	1	xx	CS (checksum)
85	1	16	End-of-message character

Table 3.1.2.9d

Load profile data structure:

The structure consists of 64 bytes.

Byte Index	Variable	Format
0	Entry number	UINT16
2	Active tariff	UINT8
3	Exponent for energy	SINT8
4	Calibratable active energy import (all phases) (mantissa 1)	UINT32
8	Calibratable active energy supply (all phases) (mantissa 1)	UINT32
12	Calibratable reactive energy import (all phases) (mantissa 1)	UINT32
16	Calibratable reactive energy supply (all phases) (mantissa 1)	UINT32
20	Two further decimal places, active energy import (mantissa 2)	UINT8
21	Two further decimal places, active energy supply (mantissa 2)	UINT8
22	Two further decimal places, reactive energy import (mantissa 2)	UINT8
23	Two further decimal places, reactive energy supply (mantissa 2)	UINT8
24	Load profile status 1	LS1
26	Load profile status 2	LS2
28	Time stamp	RTC
36	Load profile interval (1, 2, 3, 4, 5, 10, 15, 30, 60 min.)	UINT8
37 ... 63	Reserve (values not defined)	-

Table 3.1.2.9e

Note: All energy values are calculated as follows:

Display accuracy:

Energy = mantissa 1 * 10 ^ exponent register [Wh] or [VArh]

Increased accuracy:

Energy = mantissa 1 * 10 ^ exponent register + mantissa 2 * 10 ^ (exponent_for_energy-2) [Wh] or [VArh]

Calibratable energy is always saved to memory: the CT and VT values must be subsequently multiplied in the case of feature Q1 (adjustable CT and VT values, calibratable secondary energy).

Example:

Mantissa 1 of 4561 and mantissa 2 of 24 and exponent +3 is read as:

Mantissa 1, register:

00h	00h	11h	D5h
-----	-----	-----	-----

Mantissa 2, register:

00h	18h
-----	-----

Exponent register:

03h

$4561 * 10 ^ (3) + 24 * 10 ^ (1) = 4,561,240 \text{ Wh}$

Counter reading profile status

The counter reading profile status registers display events which have occurred during the counter reading profile interval.

Load profile status 1: bits 0 ... 15 come from the operating logbook for events which have occurred during the counter reading profile interval.

If the counter reading profile logger entry is incomplete (after reset, tariff change or time change), this is indicated by the "incomplete counter reading profile interval" status bit.

If a reset has occurred, for example in the case of a restart after a power failure, this is indicated in the first counter reading profile entry by means of the "reset occurred" status bit (and incomplete counter reading profile logger interval). If the tariff is changed, the current counter reading profile logger value (asynchronous entry) at the point in time of the tariff change is saved with the information "tariff change". A new counter reading profile interval is then started with the new tariff. As a result, no energy values can be lost (the entry after the tariff change and the next entry are flagged with the "incomplete counter reading profile interval" status bit).

If time is changed, the current counter reading profile logger value (asynchronous entry) is saved with the "time changed – asynchronous counter reading profile entry" status bit with the previous time stamp, after which a new counter reading profile logger period is started with the new time. As a result, no energy values can be lost (the entry after the tariff change and the next entry are flagged with the "incomplete counter reading profile interval" status bit).

15	14	13	12	11	10	9	8	7	6	5	4	3	2	1	0
----	----	----	----	----	----	---	---	---	---	---	---	---	---	---	---

MSB

Counter reading profile Status 1

Status Bit	Description
0	Current too high, phase 1
1	Current too high, phase 2
2	Current too high, phase 3
3	Voltage too high, phase 1
4	Voltage too high, phase 2
5	Voltage too high, phase 3
6	No frequency synchronization
7	Frequency too low
8	Frequency too high
9	Counterclockwise phase sequence
10	Unknown phase sequence
11	Device is not calibrated
12	Analog error
13	Energy error
14	Internal communication error
15	Energy restored – the energy value has been restored from cyclical backups.

Table 3.1.2.9f

Counter reading profile Status 2

Status Bit	Description
0	Incomplete counter reading profile interval
1	Reset occurred
2	Tariff changed – asynchronous counter reading profile entry
3	Time changed – asynchronous counter reading profile entry
4	-
5	-
6	-
7	-
8	-
9	-
10	-
11	-
12	-
13	-
14	-
15	-

Table 3.1.2.9g

RTC Format

Structure of the RTC command (date and time):

Variable	Format
Seconds	UINT8
Minutes	UINT8
Hours	UINT8
Day	UINT8
Month	UINT8
Year	UINT16

Table 3.1.2.9h

3.1.2.10 Setting the Reset Time for Resettable Meters

This function makes it possible to set the time at which resettable meters are automatically reset.

Command when using the slave's primary address:

Byte No.	Size (bytes)	Value (hex)	Description
1	1	68	Start character (long telegram)
2	1	0C	L field
3	1	0C	L field (repetition)
4	1	68	Start character (long telegram, repetition)
5	1	73	C field, SND_UD
6	1	xx	A field, primary address (00 ... FA = 0 ... 250 or 253, if selected)
7	1	51	CI field
8	1	06	DIF: 48-bit, data field = 0110b, type I
9	1	FF	VIF followed by manufacturer-specific VIFE
10	1	19	Manufacturer-specific VIFE: date and time for resetting
11 ... 16	1	xx xx xx xx xx xx	Value: type I: date and time (CP48) (see table 3.1.4.10a)
17	1	xx	CS (checksum)
18	1	16	End-of-message character

Table 3.1.2.10a

Command when using the slave's secondary address:

Byte No.	Size (bytes)	Value (hex)	Description
1	1	68	Start character (long telegram)
2	1	0F	L field
3	1	0F	L field (repetition)
4	1	68	Start character (long telegram, repetition)
5	1	73	C field, SND_UD
6	1	FD	A field, primary address = 253, i.e. addressing via the secondary address
7	1	51	CI field
8 ... 15	8	xx xx xx xx xx xx xx xx	Secondary address
16	1	06	DIF: 48-bit, data field = 0110b, type I
17	1	FF	VIF followed by manufacturer-specific VIFE
18	1	19	Manufacturer-specific VIFE: date and time for resetting
19 ... 24	1	xx xx xx xx xx xx	Value: type I: date and time (CP48) (see table 3.1.4.10a)
25	1	xx	CS (checksum)
26	1	16	End-of-message character

Table 3.1.2.10b

Response from the slave: E5h

3.1.2.11 Setting Date and Time for the Cutoff Date Function

This function makes it possible to set date and time for the cutoff date function.

Command when using the slave's primary address:

Byte No.	Size (bytes)	Value (hex)	Description
1	1	68	Start character (long telegram)
2	1	0C	L field
3	1	0C	L field (repetition)
4	1	68	Start character (long telegram, repetition)
5	1	73	C field, SND_UD
6	1	xx	A field, primary address (00 ... FA = 0 ... 250 or 253, if selected)
7	1	51	CI field
8	1	06	DIF: 48-bit, data field = 0110b, type I
9	1	FF	VIF followed by manufacturer-specific VIFE
10	1	1C	Manufacturer-specific VIFE: date and time for the cutoff date function
11 ... 16	1	xx xx xx xx xx xx	Value: type I: date and time (CP48) (see table 3.1.4.10a)
17	1	xx	CS (checksum)
18	1	16	End-of-message character

Table 3.1.2.11a

Command when using the slave's secondary address:

Byte No.	Size (bytes)	Value (hex)	Description
1	1	68	Start character (long telegram)
2	1	0F	L field
3	1	0F	L field (repetition)
4	1	68	Start character (long telegram, repetition)
5	1	73	C field, SND_UD
6	1	FD	A field, primary address = 253, i.e. addressing via the secondary address
7	1	51	CI field
8 ... 15	8	xx xx xx xx xx xx xx xx	Secondary address
16	1	06	DIF: 48-bit, data field = 0110b, type I
17	1	FF	VIF followed by manufacturer-specific VIFE
18	1	1C	Manufacturer-specific VIFE: date and time for the cutoff date function
19 ... 24	1	xx xx xx xx xx xx	Value: type I: date and time (CP48) (see table 3.1.4.10a)
25	1	xx	CS (checksum)
26	1	16	End-of-message character

Table 3.1.2.11b

Response from the slave: E5h

3.1.2.12 Setting the Counter reading profile Period

This command is used to set the counter reading profile period.

Command when using the slave's primary address:

Byte No.	Size (bytes)	Value (hex)	Description
1	1	68	Start character (long telegram)
2	1	07	L field
3	1	07	L field (repetition)
4	1	68	Start character (long telegram, repetition)
5	1	73	C field, SND_UD
6	1	xx	A field, primary address (00 ... FA = 0 ... 250 or 253, if selected)
7	1	51	CI field
8	1	01	DIF: 8-bit integer, 1 byte
9	1	FF	VIF followed by manufacturer-specific VIFE
10	1	1A	Manufacturer-specific VIFE: counter reading profile integrating period
11	1	xx	New value for the counter reading profile integrating period
12	1	xx	CS (checksum)
13	1	16	End-of-message character

Table 3.1.2.12a

Command when using the slave's secondary address:

Byte No.	Size (bytes)	Value (hex)	Description
1	1	68	Start character (long telegram)
2	1	0F	L field
3	1	0F	L field (repetition)
4	1	68	Start character (long telegram, repetition)
5	1	73	C field, SND_UD
6	1	FD	A field, primary address = 253, i.e. addressing via the secondary address
7	1	51	CI field
8 ... 15	8	xx xx xx xx xx xx xx xx	Secondary address
16	1	01	DIF: 8-bit integer, 1 byte
17	1	FF	VIF followed by manufacturer-specific VIFE
18	1	1A	Manufacturer-specific VIFE: counter reading profile integrating period
19	1	xx	New value for the counter reading profile integrating period
20	1	xx	CS (checksum)
21	1	16	End-of-message character

Table 3.1.2.12b

Response from the slave: E5h

3.1.2.13 Selecting a Slave with the Help of the Secondary Address

Command for selecting the slave via the secondary address:

Byte No.	Size (bytes)	Value (hex)	Description
1	1	68	Start character (long telegram)
2	1	0B	L field
3	1	0B	L field (repetition)
4	1	68	Start character (long telegram, repetition)
5	1	73	C field, SND_UD
6	1	FD	A field, primary address = 253, i.e. addressing via the secondary address
7	1	52	CI field
8 ... 15	8	xx xx xx xx xx xx xx xx	Secondary address UD (see relevant section)
16	1	xx	CS (checksum)
17	1	16	End-of-message character

Table 3.1.2.13: SND_UD Command: Selecting a Slave with the Help of the Secondary Address

Response from the slave: E5h

This telegram selects an M-Bus slave. After receiving REQ_UD2 with FD in the A field, a selected M-Bus slave is ready to transmit all **data**.

The M-Bus slave also accepts all telegrams with primary address FD (FD in the A field) in this mode.

In the following cases, the M-Bus slave is switched back to the normal mode:

- The M-Bus slave is switched off.
- The M-Bus slave receives an invalid telegram.
- The M-Bus slave receives a telegram for "initialization of the M-Bus slave" (SND_NKE).

3.1.2.14 Setting Parameter Masks

This function makes it possible to select the data to be read out from the slave. All data can be read out, the desired data can be selected or a default mask can be selected which contains various types of data.

Up to M bus firmware V1.15: The parameter masks are preserved until a reset is effected. Afterwards, the standard telegram is set again, see section 4.3. Standard Telegram.

As from M bus firmware V1.15, the parameter masks are stored permanently, the set telegram is thus permanently preserved.

Please note section 5.4. Set Telegram **Fehler! Verweisquelle konnte nicht gefunden werden.** and 5.5. ENERGYMID Tool **Fehler! Verweisquelle konnte nicht gefunden werden..**

Read out all data:

Command when using the slave's primary address:

Byte No.	Size (bytes)	Value (hex)	Description
1	1	68	Start character (long telegram)
2	1	04	L field
3	1	04	L field (repetition)
4	1	68	Start character (long telegram, repetition)
5	1	73	C field, SND_UD
6	1	xx	A field, primary address (00 ... FA = 0 ... 250, 253 or 255)
7	1	51	CI field
8	1	7F	DIF: read out all data
9	1	xx	CS (checksum)
10	1	16	End-of-message character

Table 3.1.2.14a: SND_UD Command: Reading Out All Data with the Help of the Primary Address

Command when using the slave's secondary address:

Byte No.	Size (bytes)	Value (hex)	Description
1	1	68	Start character (long telegram)
2	1	0C	L field
3	1	0C	L field (repetition)
4	1	68	Start character (long telegram, repetition)
5	1	73	C field, SND_UD
6	1	FD	A field, primary address = 253, i.e. addressing via the secondary address
7	1	51	CI field
8 ... 15	8	xx xx xx xx xx xx xx xx	Secondary address
16	1	7F	DIF: query, read out all data
17	1	xx	CS (checksum)
18	1	16	End-of-message character

Table 3.1.2.14b: SND_UD Command: Reading Out All Data with the Help of the Secondary Address

Response from the slave: E5h

Read out desired data:

Command when using the slave's primary address:

Byte No.	Size (bytes)	Value (hex)	Description
1	1	68	Start character (long telegram)
2	1	13	L field
3	1	13	L field (repetition)
4	1	68	Start character (long telegram, repetition)
5	1	73	C field, SND_UD
6	1	xx	A field, primary address (00..FA, FD, FF = 0..250, 253, 255)
7	1	51	CI field
8	1	0D	DIF: variable length
9	1	FD	VIF followed by standard VIFE
10	1	0B	VIFE: parameter mask identification
11	1	0C	LVAR=12
12	1	"PS0"	Selected parameter from parameter mask 0
13	1	"PS1"	Selected parameter from parameter mask 1
14	1	"PS2"	Selected parameter from parameter mask 2
15	1	"PS3"	Selected parameter from parameter mask 3
16	1	"PS4"	Selected parameter from parameter mask 4
17	1	"PS5"	Selected parameter from parameter mask 5
18	1	"PS6"	Selected parameter from parameter mask 6
19	1	"PS7"	Selected parameter from parameter mask 7
20	1	"PS8"	Selected parameter from parameter mask 8
21	1	"PS9"	Selected parameter from parameter mask 9
22	1	"PS10"	Selected parameter from parameter mask 10
23	1	"PS11"	Selected parameter from parameter mask 11
24	1	Xx	CS (checksum)
25	1	16	End-of-message character

Table 3.1.2.14c: SND_UD Command: Reading Out Desired Data with the Help of the Primary Address

In order to set the parameter mask for all M-Bus interfaces, primary address 255 (FFh) must be used in the A field. In this case, the M-Bus interfaces don't send an acknowledgement telegram (E5h).

See section 4.3. Standard Telegram concerning the default parameter mask for **single frame** communication after a START or a RESET.

Command when using the slave's secondary address:

Byte No.	Size (bytes)	Value (hex)	Description
1	1	68	Start character (long telegram)
2	1	1B	L field
3	1	1B	L field (repetition)
4	1	68	Start character (long telegram, repetition)
5	1	73	C field, SND_UD
6	1	FD	A field, primary address = 253, i.e. addressing via the secondary address
7	1	51	CI field
8 ... 15	8	xx xx xx xx xx xx xx xx	Secondary address (see relevant section)
16	1	0D	DIF: variable length
17	1	FD	VIF followed by standard VIFE
18	1	0B	VIFE: parameter set identification
19	1	0C	LVAR=12
20	1	"PS0"	Selected parameter from parameter mask 0
21	1	"PS1"	Selected parameter from parameter mask 1
22	1	"PS2"	Selected parameter from parameter mask 2
23	1	"PS3"	Selected parameter from parameter mask 3
24	1	"PS4"	Selected parameter from parameter mask 4
25	1	"PS5"	Selected parameter from parameter mask 5
26	1	"PS6"	Selected parameter from parameter mask 6
27	1	"PS7"	Selected parameter from parameter mask 7
28	1	"PS8"	Selected parameter from parameter mask 8
29	1	"PS9"	Selected parameter from parameter mask 9
30	1	"PS10"	Selected parameter from parameter mask 10
31	1	"PS11"	Selected parameter from parameter mask 11
32	1	Xx	CS (checksum)
33	1	16	End-of-message character

Table 3.1.2.14d: SND_UD Command: Reading Out Desired Data with the Help of the Secondary Address

Response from the slave: E5h

Default parameter mask for the **Single Frame** communication after START or RESET see section 4.3. Standard Telegram.

Please note sections 5.4. Set Telegram and 5.5. ENERGYMID Tool **Fehler! Verweisquelle konnte nicht gefunden werden..**

Temporary Read-out of the Desired Files:

Applicable as from M bus firmware version V1.15.

With this mask the data can be read out temporarily. The protocol is not changed permanently. This protocol is used for communication by the ENERGYMID tool.

Command for Using the Primary Address of the Slaves:

Byte No.	Size (Byte)	Value (hex)	Description
1	1	68	Start character (long telegram)
2	1	13	L field
3	1	13	L field (repetition)
4	1	68	Start character (long telegram, repetition)
5	1	73	C field, SND_UD
6	1	xx	A field, primary address (00..FA, FD, FF = 0..250, 253, 255 and FF = 255)
7	1	51	CI field
8	1	0D	DIF: variable length
9	1	FF	VIF: followed by standard VIFE
10	1	51	VIFE: parameter set identification
11	1	0C	LVAR=12
12	1	"PS0"	Selected parameter from parameter mask 0
13	1	"PS1"	Selected parameter from parameter mask 1
14	1	"PS2"	Selected parameter from parameter mask 2
15	1	"PS3"	Selected parameter from parameter mask 3
16	1	"PS4"	Selected parameter from parameter mask 4
17	1	"PS5"	Selected parameter from parameter mask 5
18	1	"PS6"	Selected parameter from parameter mask 6
19	1	"PS7"	Selected parameter from parameter mask 7
20	1	"PS8"	Selected parameter from parameter mask 8
21	1	"PS9"	Selected parameter from parameter mask 9
22	1	"PS10"	Selected parameter from parameter mask 10
23	1	"PS11"	Selected parameter from parameter mask 11
24	1	xx	CS (checksum)
25	1	16	End-of-message character

Table 3.1.2.14c – SND_UD Command: Reading Out Desired Data with the Help of the Primary Address

3.1.3 REQ_UD2

This procedure is used by the M-Bus master in order to request data from the slave. The slave acknowledges correct receipt of the telegram with the RSP_UD response, or doesn't respond if the telegram has not been correctly received. The slave sends the requested data with the SND_UD command.

Structure of the REQ_UD2 command:

Byte No.	Size (bytes)	Value (hex)	Description
1	1	10	Start character (short telegram)
2	1	7B / 5B	C field, transmission of a read-out command
3	1	Xx	A field – primary address 00..FA: valid primary address FB, FC: reserved for future use FD: addressing via secondary address FE: transmission to all M-Bus participants with response (all slaves respond with E5h) FF: transmission to all M-Bus participants without response (no slaves respond)
4	1	Xx	CS (checksum)
5	1	16	End-of-message character

Table 3.1.3: REQ_UD2 Command

Response from the slave: RSP_UD

3.1.4 RSP_UD

This procedure is used by the M-Bus slave in order to send the requested data to the master. The characteristics of the multi-frame answer are explained in appendix A.

Structure of the RSP_UD command:

Byte No.	Size (bytes)	Value (hex)	Description
1	1	68	Start character (long telegram)
2	1	xx	L field
3	1	xx	L field (repetition)
4	1	68	Start character (long telegram, repetition)
5	1	08 / 18	C field RSP_UD
6	1	xx	A field, primary address
7	1	72	CI field
8 ... 11	4	xx xx xx xx	M-Bus interface ID number
12 ... 13	2	xx xx	Manufacturer code
14	1	xx	Version number of the M-Bus interface firmware (00 ... FF)
15	1	02	Medium: electricity
16	1	xx	Access number (00 ... FF > 00)
17	1	xx	M-Bus interface status (see section on error flags)
18 ... 19	2	0000	Signature (always 0000, i.e. not used)
20 ... YY	0 ... EA	xx ... xx	Parameterized read-out data (see following section)
YY + 1	1	0F / 1F	DIF: 0F = no further data, 1F = more data to be transmitted
YY + 2	1	xx	CS (checksum)
YY + 3	1	16	End-of-message character

Table 3.14: RSP_UD Command

Possible parameterized read-out data will follow, which can be returned to byte no. 20 ... YY.

3.1.4.1 Error Status Flags

Byte No.	Size (bytes)	Value (hex)	Description
YY	1	04	DIF: 32-bit integer, 4-byte
YY + 1	1	FD	VIF followed by standard VIFE
YY + 2	1	17	VIFE: error flags (binary)
YY + 3 ... YY + 4	2	xx xx	Value: error status flags 1
YY + 5 ... YY + 6	2	xx xx	Value: error status flags 2

Table 3.1.4.1a: Error Status Flags

Error Status Flags 1

This register contains the following error bits:

MSB

LSB

NoCal		I3Hi	I2Hi	I1Hi	U3Hi	U2Hi	U1Hi		DCerr	I3Lo	I2Lo	I1Lo	U3Lo	U2Lo	U1Lo
-------	--	------	------	------	------	------	------	--	-------	------	------	------	------	------	------

Error Bit	Description
U1Lo	U1 < 75% Un
U2Lo	U2 < 75% Un
U3Lo	U3 < 75% Un
I1Lo	I1 < start-up
I2Lo	I2 < start-up
I3Lo	I3 < start-up
DC err	DC offset too high
	Free
U1Hi	U1 > 120% Un
U2Hi	U2 > 120% Un
U3Hi	U3 > 120% Un
I1Hi	Maximum value for I1 exceeded
I2Hi	Maximum value for I2 exceeded
I3Hi	Maximum value for I3 exceeded
	Free
NoCal	Device is not calibrated

Table 3.1.4.1b

Error Status Flags 2

This register contains the following error bits:

MSB

LSB

										NRUM	FRUM		FSYNC	FHi	FLo	FNo
--	--	--	--	--	--	--	--	--	--	------	------	--	-------	-----	-----	-----

Error Bit	Description
FNo	No frequency synchronization
FLo	Frequency < 40 Hz
FHi	Frequency > 70 Hz
FSYNC	Cumulative frequency error
	Free
FRUM	Incorrect direction of rotation
NRUM	No direction of rotation detected
	Free
	Free
	Free
	Free
	Free
	Free
	Free
	Free
	Free
	Free
	Free

Table 3.1.4.1c

3.1.4.2 Voltages

Byte No.	Size (bytes)	Value (hex)	Description
YY	1	02	DIF: 16-bit integer, 2-byte
YY + 1	1	FD	VIF followed by standard VIFE
YY + 2	1	Cx	VIFE: momentary voltage followed by VIFE 0xC0 .. Multiplier 10 ⁻⁹ 0xCF .. Multiplier 10 ⁺⁶
YY + 3	1	FF	VIFE followed by manufacturer-specific VIFE
YY + 4	1	xx	Manufacturer-specific VIFE: 0x00: mean value of phase voltages to N 0x01: voltage between phase L1 and N 0x02: voltage between phase L2 and N 0x03: voltage between phase L3 and N 0x05: voltage between phases L1 and L2 0x06: voltage between phases L2 and L3 0x07: voltage between phases L3 and L1 0x08: mean value of phase voltages to each other
YY + 5 – YY + 6	2	xx xx	Value

Table 3.1.4.2: Voltages

3.1.4.3 THD of the Voltages

Byte No.	Size (bytes)	Value (hex)	Description
YY	1	02	DIF: 16-bit integer, 2-byte
YY + 1	1	FF	VIF followed by manufacturer-specific VIFE
YY + 2	1	90	Manufacturer-specific VIFE: THD voltage (steps of 0.001)
YY + 3	1	FF	VIF followed by manufacturer-specific VIFE
YY + 4	1	xx	Manufacturer-specific VIFE: 0x01: phase 1 0x02: phase 2 0x03: phase 3
YY + 5 ... YY + 6	2	xx xx	Value

Table 3.1.4.3: THD of the Voltages

3.1.4.4 Currents

Byte No.	Size (bytes)	Value (hex)	Description
YY	1	02	DIF: 16-bit integer, 2-byte
YY + 1	1	FD	VIF followed by standard VIFE
YY + 2	1	Dx	VIFE: momentary voltage followed by VIFE 0xD0 ... multiplier 10 ⁻¹² 0xDF ... multiplier 10 ⁺³
YY + 3	1	FF	VIFE followed by manufacturer-specific VIFE
YY + 4	1	xx	Manufacturer-specific VIFE: 0x01: phase L1 0x02: phase L2 0x03: phase L3 0x00: phase mean 0x04: neutral
YY + 5 ... YY + 7	4	xx xx	Value

Table 3.1.4.4: Currents

3.1.4.5 THD of the Currents

Byte No.	Size (bytes)	Value (hex)	Description
YY	1	02	DIF: 16-bit integer, 2-byte
YY + 1	1	FF	VIFE followed by manufacturer-specific VIFE
YY + 2	1	91	Manufacturer-specific VIFE: THD current (steps of 0.001)
YY + 3	1	FF	VIFE followed by manufacturer-specific VIFE
YY + 4	1	xx	Manufacturer-specific VIFE: 0x01: phase L1 0x02: phase L2 0x03: phase L3
YY + 5 ... YY + 6	2	xx xx	Value

Table 3.1.4.5: THD of the Currents

3.1.4.6 Frequency

Byte No.	Size (bytes)	Value (hex)	Description
YY	1	02	DIF: 16-bit integer, 2-byte
YY + 1	1	FF	VIF followed by manufacturer-specific VIFE
YY + 2	1	12	Manufacturer-specific VIFE: Frequency (unit: 0.01 Hz)
YY + 3 ... YY + 4	2	xx xx	Value: frequency

Table 3.1.4.6: Frequency

3.1.4.7 Power

Byte No.	Size (bytes)	Value (hex)	Description
YY	1	82	DIF: 16-bit integer, 2-byte, followed by DIFE
YY + 1	1	xx	First DIFE (see section 2.2.2.1)
YY + 2	1	xx	Second DIFE (see section 2.2.2.1)
YY + 3	1	Ax	VIF: power followed by VIFE 0xA8 ... multiplier 10 ⁻³ 0xAF ... multiplier 10 ⁺⁴
YY + 4	1	FF	VIFE followed by manufacturer-specific VIFE
YY + 5	1	xx	Manufacturer-specific VIFE: 0x01: phase L1 0x02: phase L2 0x03: phase L3 0x09: total
YY + 6 ... YY + 7	2	xx xx	Value: power

Table 3.1.4.7a: Power (multiplier ≤ 10⁺⁴)

Byte No.	Size (bytes)	Value (hex)	Description
YY	1	82	DIF: 16-bit integer, 2-byte, followed by DIFE
YY + 1	1	xx	First DIFE (see section 2.2.2.1)
YY + 2	1	xx	Second DIFE (see section 2.2.2.1)
YY + 3	1	FB	Extended VIFE follows
YY + 4	1	xx	VIF: power followed by VIFE 0xA8 ... multiplier 10 ⁺⁵ 0xA9 ... multiplier 10 ⁺⁶
YY + 5	1	FF	VIFE followed by manufacturer-specific VIFE
YY + 6	1	xx	Manufacturer-specific VIFE: 0x01: phase L1 0x02: phase L2 0x03: phase L3 0x09: total
YY + 7 ... YY + 8	2	xx xx	Value: power

Table 3.1.4.7b: Power (multiplier > 10⁺⁴)

3.1.4.8 Power Factor PF

Byte No.	Size (bytes)	Value (hex)	Description
YY	1	02	DIF: 16-bit integer, 2-byte
YY + 1	1	FF	VIF followed by manufacturer-specific VIFE
YY + 2	1	93	Manufacturer-specific VIFE: power factor PF (steps of 0.001)
YY + 3	1	FF	VIF followed by manufacturer-specific VIFE
YY + 4	1	xx	Manufacturer-specific VIFE: 0x01: phase L1 0x02: phase L2 0x03: phase L3 0x09: total
YY + 5 ... YY + 6	2	xx xx	Value: power factor PF

Table 3.1.4.8: Power Factor PF

3.1.4.9 Energy

Invalid energy values (reactive energy for meters without reactive energy metering) are indicated by the value 80000000h.

Byte No.	Size (bytes)	Value (hex)	Description
YY	1	84	DIF: 32-bit integer, 4-byte, followed by DIFE
YY + 1	1	xx	First DIFE (see section 2.2.2.1)
YY + 2	1	xx	Second DIFE (see section 2.2.2.1)
YY + 3	1	xx	Third DIFE (see section 2.2.2.1)
YY + 4	1	8x	VIF: energy followed by VIFE 0x80 ... multiplier 10 ⁻³ 0x87 ... multiplier 10 ⁺⁴
YY + 5	1	FF	VIFE followed by manufacturer-specific VIFE
YY + 6	1	xx	Manufacturer-specific VIFE: 0x01: phase L1 0x02: phase L2 0x03: phase L3 0x09: total
YY + 7 ... YY + 10	4	xx xx xx xx	Value: energy

Table 3.1.4.9a: Energy (multiplier ≤ 10⁺⁴)

Byte No.	Size (bytes)	Value (hex)	Description
YY	1	84	DIF: 32-bit integer, 4-byte, followed by DIFE
YY + 1	1	xx	First DIFE (see section 2.2.2.1)
YY + 2	1	xx	Second DIFE (see section 2.2.2.1)
YY + 3	1	xx	Third DIFE (see section 2.2.2.1)
YY + 4	1	FB	Extended VIFE follows
YY + 5	1	80	VIF: energy followed by VIFE 0x80 .. Multiplier 10 ⁺⁵
YY + 6	1	FF	VIFE followed by manufacturer-specific VIFE
YY + 7	1	xx	Manufacturer-specific VIFE: 0x01: phase L1 0x02: phase L2 0x03: phase L3 0x09: total
YY + 8 ... YY + 11	4	xx xx xx xx	Value: energy

Table 3.1.4.9b: Energy (multiplier > 10⁺⁴)

3.1.4.10 Date and Time

Byte No.	Size (bytes)	Value (hex)	Description
YY	1	06	DIF: data field = 0110b, type I
YY + 1	1	6D	VIF: date and time
YY + 2 ... YY + 7	6	xx xx xx xx xx xx	Value: type I: date and time (CP48) (see table 3.1.4.10a)

Table 3.1.4.10: Date and Time

Table 3.1.4.10a: Type I – Date and Time (CP48)

Byte/Bit	MSBit							LSBit
LSByte	8	7	6	5	4	3	2	1
	16	15	14	13	12	11	10	9
	24	23	22	21	20	19	18	17
	32	31	30	29	28	27	26	25
	40	39	38	37	36	35	34	33
MSByte	48	47	46	45	44	43	42	41

Seconds	UI6 [1 ... 6]	< 0 ... 59 >
Minutes	UI6 [9 ... 14]	< 0 ... 59 >
Hours	UI5 [17 ... 21]	< 0 ... 23 >
Day	UI5 [25 ... 29]	< 1 ... 31 >
Month	UI4 [33 ... 36]	< 1 ... 12 >
Year	UI7 [30 ... 32 + 37 ... 40]	< 0 ... 99 >

The other bits are zero.

3.1.4.11 Current Tariff

Byte No.	Size (bytes)	Value (hex)	Description
YY	1	01	DIF: 8-bit integer, 1-byte
YY + 1	1	FF	VIF followed by manufacturer-specific VIFE
YY + 2	1	14	Manufacturer-specific VIFE: current tariff
YY + 3	1	xx	Value: current tariff (0x01 - 0x08)

Table 3.1.4.11: Current Tariff

3.1.4.12 Current Transformer Ratio (CT)

Byte No.	Size (bytes)	Value (hex)	Description
YY	1	02	DIF: 16-bit integer, 2-byte
YY + 1	1	FF	VIF followed by manufacturer-specific VIFE
YY + 2	1	15	Manufacturer-specific VIFE: CT value
YY + 3 ... YY + 4	2	xx xx	Value: CT value

Table 3.1.4.12

3.1.4.13 Voltage Transformer Ratio (VT)

Byte No.	Size (bytes)	Value (hex)	Description
YY	1	02	DIF: 16-bit integer, 2-byte
YY + 1	1	FF	VIF followed by manufacturer-specific VIFE
YY + 2	1	16	Manufacturer-specific VIFE: VT value
YY + 3 ... YY + 4	2	xx xx	Value: VT value

Table 3.1.4.13

3.1.4.14 Counter reading profile Integrating Period (with feature Z1 only)

Byte No.	Size (bytes)	Value (hex)	Description
YY	1	01	DIF: 8-bit integer, 1-byte
YY + 1	1	FF	VIF followed by manufacturer-specific VIFE
YY + 2	1	1A	Manufacturer-specific VIFE: counter reading profile integrating period
YY + 3	1	xx	Value: counter reading profile integrating period

Table 3.1.4.14: Counter reading profile Integrating Period (with feature Z1 only)

3.1.4.15 Features

Byte No.	Size (bytes)	Value (hex)	Description
YY	1	0D	DIF: variable length
YY + 1	1	FF	VIF followed by manufacturer-specific VIFE
YY + 2	1	1B	Manufacturer-specific VIFE: features
YY + 3	1	47	LVAR = 71d
YY + 4 ... YY + 47	71	xx-xx	Features

Table 3.1.4.15: Features

3.1.4.16 Preset Date and Time of the Cutoff Date

Byte No.	Size (bytes)	Value (hex)	Description
YY	1	06	DIF: data field = 0110b, type I
YY + 1	1	FF	VIF followed by manufacturer-specific VIFE
YY + 2	1	1C	Manufacturer-specific VIFE: date and time of the cutoff date
YY + 3 ... YY + 8	6	xx xx xx xx xx xx	Value: type I: date and time (CP48) (see table 3.1.4.10a)

Table 3.1.4.16: Date and Time of the Cutoff Date

3.1.4.17 Preset Date and Time for Resetting the Resettable Meters

Byte No.	Size (bytes)	Value (hex)	Description
YY	1	06	DIF: data field = 0110b, type I
YY + 1	1	FF	VIF followed by manufacturer-specific VIFE
YY + 2	1	19	Manufacturer-specific VIFE: preset reset time for resettable meters
YY + 3 ... YY + 8	6	xx xx xx xx xx xx	Value: type I: date and time (CP48) (see table 3.1.4.10a)

Table 3.1.4.17: Preset Date and Time for Resetting the Resettable Meters

3.1.4.18 Time Stamp of the last Cutoff Date

Byte No.	Size (bytes)	Value (hex)	Description
YY	1	06	DIF: data field = 0110b, type I
YY + 1	1	FF	VIF followed by manufacturer-specific VIFE
YY + 2	1	1E	Manufacturer-specific VIFE: time stamp for resettable meters
YY + 3 ... YY + 8	6	xx xx xx xx xx xx	Value: type I: date and time (CP48) (see table 3.1.4.10a)

Table 3.1.4.18: Time Stamp of the last Cutoff Date

3.1.4.19 Date and Time for Resetting

Byte No.	Size (bytes)	Value (hex)	Description
YY	1	06	DIF: data field = 0110b, type I
YY + 1	1	FF	VIF followed by manufacturer-specific VIFE
YY + 2	1	1D	Manufacturer-specific VIFE: date and time for resetting
YY + 3 ... YY + 8	6	xx xx xx xx xx xx	Value: type I: date and time (CP48) (see table 3.1.4.10a)

Table 3.1.4.19: Date and Time for Resetting

3.1.4.20 Total Operating Hours

Byte No.	Size (bytes)	Value (hex)	Description
YY	1	04	DIF: 32-bit integer, 4-byte
YY + 1	1	22	VIF
YY + 2 ... YY + 5	4	xx xx xx xx	Value: total operating hours

Table 3.1.4.20: Total Operating Hours

3.1.4.21 Operating Hours Since Last Reset

Byte No.	Size (bytes)	Value (hex)	Description
YY	1	02	DIF: 16-bit integer, 2-byte
YY + 1	1	FF	VIF followed by manufacturer-specific VIFE
YY + 2	1	20	Manufacturer-specific VIFE: operating hours since last reset
YY + 3 ... YY + 4	2	xx xx	Value: operating hours since last reset

Table 3.1.4.21: Operating Hours Since Last Reset

3.1.4.22 Version

Byte No.	Size (bytes)	Value (hex)	Description
YY	1	04	DIF: 32-bit integer, 4-byte
YY + 1	1	FF	VIF followed by manufacturer-specific VIFE
YY + 2	1	22	Manufacturer-specific VIFE: version
YY + 3	1	xx	Hardware version, units digit
YY + 4	1	xx	Hardware version, tens digit
YY + 5	1	xx	Firmware version, units digit
YY + 6	1	xx	Firmware version, tens digit

Table 3.1.4.22: Version

4 Appendix

4.1 Communication Procedure

Communication procedure in the case of a **single frame** RSP_UD response from the slave, e.g. the standard telegram:



This means that in both cases, the last data block of the RSP_UD response must be **0Fh**.

Communication procedure in the case of a **multi-frame** RSP_UD response, e.g. 2 frames:

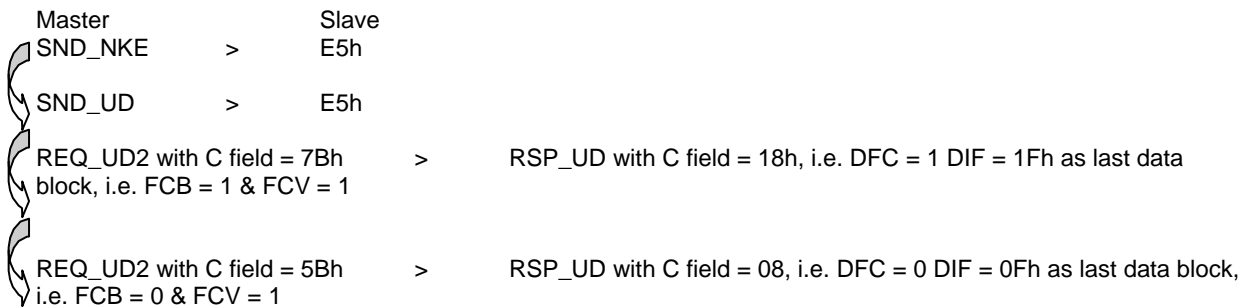

This means that in both cases, the last data block of the RSP_UD response must be **0Fh**.

4.2 Parameter Set List – All Retrievable Values

The bit distribution for each parameter set byte is shown below.

All energy values are always import and export, and thus comprise two data points.

Bit No.	Selected Files	OBIS	Order	Bit	Parameter Set
1	Error status flags		8	xxxx xxx1b	PS0
2	Primary voltage between phase and N		11	xxxx xx1xb	
3	Primary voltage between the phases		12	xxxx x1xxb	
4	THD voltage		13	xxxx 1xxxb	
5	Primary current		14	xxx1 xxxxb	
6	THD current		15	xx1x xxxxb	
7	Frequency		16	x1xx xxxxb	
8	Primary active energy – total		9	1xxx xxxxb	
9	Primary reactive energy – total		10	xxxx xxx1b	PS1
10	Power factor (PF)		17	xxxx xx1xb	
11	Secondary active power		18	xxxx x1xxb	
12	Load profile integrating period		19	xxxx 1xxxb	
13	Date, time		1	xxx1 xxxxb	
14	Active energy, total (all tariffs)	1(2).8.0	3	xx1x xxxxb	
15	Reactive energy, total (all tariffs)	3(4).8.0	4	x1xx xxxxb	
16	Displays the current tariff		5	1xxx xxxxb	
17	Active energy of the active tariff		6	xxxx xxx1b	PS2
18	Reactive energy of the active tariff		7	xxxx xx1xb	
19	Tariff 1, active energy	1(2).8.1	20	xxxx x1xxb	
20	Tariff 1, reactive energy	3(4).8.1	21	xxxx 1xxxb	
21	Tariff 2, active energy	1(2).8.2	22	xxx1 xxxxb	
22	Tariff 2, reactive energy	3(4).8.2	23	xx1x xxxxb	
23	Tariff 3, active energy	1(2).8.3	24	x1xx xxxxb	
24	Tariff 3, reactive energy	3(4).8.3	25	1xxx xxxxb	
25	Tariff 4, active energy	1(2).8.4	26	xxxx xxx1b	PS3
26	Tariff 4, reactive energy	3(4).8.4	27	xxxx xx1xb	
27	Tariff 5, active energy	1(2).8.5	28	xxxx x1xxb	
28	Tariff 5, reactive energy	3(4).8.5	29	xxxx 1xxxb	
29	Tariff 6, active energy	1(2).8.6	30	xxx1 xxxxb	
30	Tariff 6, reactive energy	3(4).8.6	31	xx1x xxxxb	
31	Tariff 7, active energy	1(2).8.7	32	x1xx xxxxb	

Bit No.	Selected Files	OBIS	Order	Bit	Parameter Set
32	Tariff 7, reactive energy	3(4).8.7	33	1xxx xxxxb	
33	Tariff 8, active energy	1(2).8.8	34	xxxx xxx1b	PS4
34	Tariff 8, reactive energy	3(4).8.8	35	xxxx xx1xb	
35	Current transformer ratio (CT)		36	xxxx x1xxb	
36	Voltage transformer ratio (VT)		37	xxxx 1xxxb	
37	Resettable active energy from tariff 1		38	xxx1 xxxxb	
38	Resettable reactive energy from tariff 1		39	xx1x xxxxb	
39	Resettable active energy from tariff 2		40	x1xx xxxxb	
40	Resettable reactive energy from tariff 2		41	1xxx xxxxb	
41	Resettable active energy from tariff 3		42	xxxx xxx1b	PS5
42	Resettable reactive energy from tariff 3		43	xxxx xx1xb	
43	Resettable active energy from tariff 4		44	xxxx x1xxb	
44	Resettable reactive energy from tariff 4		45	xxxx 1xxxb	
45	Resettable active energy from tariff 5		46	xxx1 xxxxb	
46	Resettable reactive energy from tariff 5		47	xx1x xxxxb	
47	Resettable active energy from tariff 6		48	x1xx xxxxb	
48	Resettable reactive energy from tariff 6		49	1xxx xxxxb	
49	Resettable active energy from tariff 7		50	xxxx xxx1b	PS6
50	Resettable reactive energy from tariff 7		51	xxxx xx1xb	
51	Resettable active energy from tariff 8		52	xxxx x1xxb	
52	Resettable reactive energy from tariff 8		53	xxxx 1xxxb	
53	Active energy, tariff 1, on cutoff date		54	xxx1 xxxxb	
54	Reactive energy, tariff 1, on cutoff date		55	xx1x xxxxb	
55	Active energy, tariff 2, on cutoff date		56	x1xx xxxxb	
56	Reactive energy, tariff 2, on cutoff date		57	1xxx xxxxb	
57	Active energy, tariff 3, on cutoff date		58	xxxx xxx1b	PS7
58	Reactive energy, tariff 3, on cutoff date		59	xxxx xx1xb	
59	Active energy, tariff 4, on cutoff date		60	xxxx x1xxb	
60	Reactive energy, tariff 4, on cutoff date		61	xxxx 1xxxb	
61	Active energy, tariff 5, on cutoff date		62	xxx1 xxxxb	
62	Reactive energy, tariff 5, on cutoff date		63	xx1x xxxxb	
63	Active energy, tariff 6, on cutoff date		64	x1xx xxxxb	
64	Reactive energy, tariff 6, on cutoff date		65	1xxx xxxxb	
65	Active energy, tariff 7, on cutoff date		66	xxxx xxx1b	PS8

Bit No.	Selected Files	OBIS	Order	Bit	Parameter Set
66	Reactive energy, tariff 7, on cutoff date		67	xxxx xx1xb	
67	Active energy, tariff 8, on cutoff date		68	xxxx x1xb	
68	Reactive energy, tariff 8, on cutoff date		69	xxxx 1xxxb	
69	Features		70	xxx1 xxxxb	
70	Selected time for cutoff date function		71	xx1x xxxxb	
71	Preset time for resetting the resettable meters		72	x1xx xxxxb	
72	Date and time of the cutoff date		73	1xxx xxxxb	
73	Date and time for resetting		74	xxxx xxx1b	PS9
74	Operating hours		2	xxxx xx1xb	
75	Operating hours since last reset		75	xxxx x1xb	
76	Version		76	xxxx 1xxxb	
77	Tariff specified via the interface (1 - 8) or 0 in case of tariff control via the hardware inputs		77	xxx1 xxxxb	
78	Primary active power from phase 1		78	xx1x xxxxb	
79	Primary active power from phase 2		79	x1xx xxxxb	
80	Primary active power from phase 3		80	1xxx xxxxb	PS10
81	Primary reactive power from phase 1		81	xxxx xxx1b	
82	Primary reactive power from phase 2		82	xxxx xx1xb	
83	Primary reactive power from phase 3		83	xxxx x1xb	PS11
reserved				xxxx 1xxxb	
				xxx1 xxxxb	
				xx1x xxxxb	
				x1xx xxxxb	
				1xxx xxxxb	
				xxxx xxx1b	
				xxxx xx1xb	
				xxxx x1xb	
				xxxx 1xxxb	
				xxx1 xxxxb	
			xx1x xxxxb		
			x1xx xxxxb		
			1xxx xxxxb		

Table 4.2: Bit Distribution for Each Parameter Set Byte

4.3. Standard Telegram

With up to and including M-Bus firmware version V1.10, a default parameters set is initiated for all phases, which follows its own sequence, when the meter is started up or after a power failure or an undervoltage event.

This corresponds to the default status upon shipment for meters with M-Bus firmware as of version 1.15.

This results in the following standard telegram:

ParameterSet[1]	xxx1 xxxxb	date, time
ParameterSet[9]	xxxx xx1xb	total operating hours
ParameterSet[1]	xx1x xxxxb	total primary active energy (all tariffs), import total primary active energy (all tariffs), export
ParameterSet[1]	x1xx xxxxb	total primary reactive energy (all tariffs), import total primary reactive energy (all tariffs), export
ParameterSet[1]	1xxx xxxxb	active tariff
ParameterSet[0]	xxxx xxx1b	error status flags
ParameterSet[0]	1xxx xxxxb	primary active power (sum of all phases)
ParameterSet[1]	xxxx xxx1b	primary reactive power (sum of all phases)

In this case **single frame** communication is involved and all values are transmitted in a single block: each new query results in current values.

Refer to section 5.4. Set Telegram, in order to set up your own frame.

5 Application Notes

Important Note: Only use ENERGYMID tool versions V1.17 or higher for meters with M bus firmware from V1.15 onwards.

5.1 Operating Logbook and Counter Reading Profile (feature Z1)

The operating logbook and the counter reading profile are read out sequentially from the latest to the oldest entry. The procedure is as follows:

- First of all, the last entry is read.
- The next older entry is repeatedly retrieved thereafter.
- In the event of transmission problems etc., it's possible re-access previously read values.

Contents of the operating logbook:

- Events are logged with time stamp.
- Event are logged once again when they disappear and their disappearance is indicated.
- Parameter: Relevant parameters are also logged depending on the event.

Load profile functions (feature Z1):

- At the end of each integrating period, all 4 energy values for the current tariff are saved to memory with enhanced accuracy along with time stamp and status.
- The calibratable energy values are always saved, and thus must be taken into consideration in the evaluation in the case of meters with adjustable CT/VT values.
- The integrating period is always ended synchronous to clock time, unless an event causes switching to a new period (e.g. tariff change, time change).
- The status represents a cumulative view of events which have occurred during the integrating period.
- Incomplete integrating periods are identified.
- In the case of a tariff change or a time change, the integrating period is interrupted, the value is stored along with the old tariff or time and a new period is started.

5.2 Cutoff Date Meter

The point in time at which the meter readings will be "frozen" can be preselected by setting date and time for the cutoff date function (see section 3.1.2.11), i.e. the current energy value status is copied to a separate data range and can be read out later (cutoff date energy values). It's also still possible to retrieve the point in time of the last cutoff date (see section 3.1.4.18). Cutoff date energy values for tariffs 1 through 8 can be retrieved with the help of the parameter set list (see section 4.2).

The following rules apply to the specification of a cutoff date:

- Point in time in the future: cutoff date energy values are updated at this point in time.
- Point in time in the past: no updating of cutoff date energy values.
- Current date, time of day in the past: current device time and cutoff date energy values are saved to memory.
- An entry of 0 to day, month or year functions as a placeholder: the cutoff date energy values are updated on each corresponding date.
- Everything in date and time set to 0 (placeholder): cutoff date via device clock, every day at midnight, initial recording immediately.

5.3 Resettable Meter

Similar to the cutoff date meter, meter readings are saved and the respective differential value (= current value - value at the time of resetting) is determined.

The date and time at which the meter readings will be reset can be preselected by setting the reset time (see section 3.1.2.10).

Date and time of the completed reset operation can be read out in accordance with table 3.1.4.19. The energy readings for tariffs 1 through 8 of the resettable meter can be retrieved with the help of the parameter set list (see section 4.2).

The following rules apply to the specification of a reset time point:

- Point in time in the future: reset at this point in time.
- Point in time in the past: no resetting of energy values.
- Current date, time of day in the past: immediate reset with current device clock time.
- An entry of 0 to day, month or year functions as a placeholder: the energy values are reset on each corresponding date.
- Everything in date and time set to 0 (placeholder): reset via device clock, every day at midnight, initial reset immediately.

5.4. Set Telegram

Comment on versions: as from version V1.15, the last protocol setting is preserved in the event of a voltage failure.

The parameter configuration of the protocol can be set via the PS field. Setting can be done either via command (Section 3.1.2.14 Setting Parameter Masks **Fehler! Verweisquelle konnte nicht gefunden werden.**) or by means of the ENERGYMID tool (version V1.17).

Example: Command for the configuration of the standard telegram:

With this command you can configure via address 01

68 13 13 68 73 **01** 51 0D FD 0B 0C 81 F1 00 00 00 00 00 00 02 00 00 5A 16

Device Setting – Command: PS Field – configure

5.5. ENERGYMID Tool

Important note: Only use ENERGYMID tool versions V1.17 or higher for meters with M bus firmware from V1.15 onwards.

The following new functions are available as from ENERGYMID tool version V1.17:

- 1) For energy meter (M bus) firmware up to V1.10, the ENERGYMID tool sends out a standard command (it resets the telegram to the standard telegram).
- 2) As from version V1.15, the ENERGYMID tool does not change the telegram format permanently, but only temporarily up to the next SND_NKE telegram. This telegram is sent upon "Cut connection".
- 3) The communication can now be directly displayed in the tool via the button „Display connection“.
- 4) The telegram can now be configured in the menu field "Device Setting" by means of the command "Set PS field".

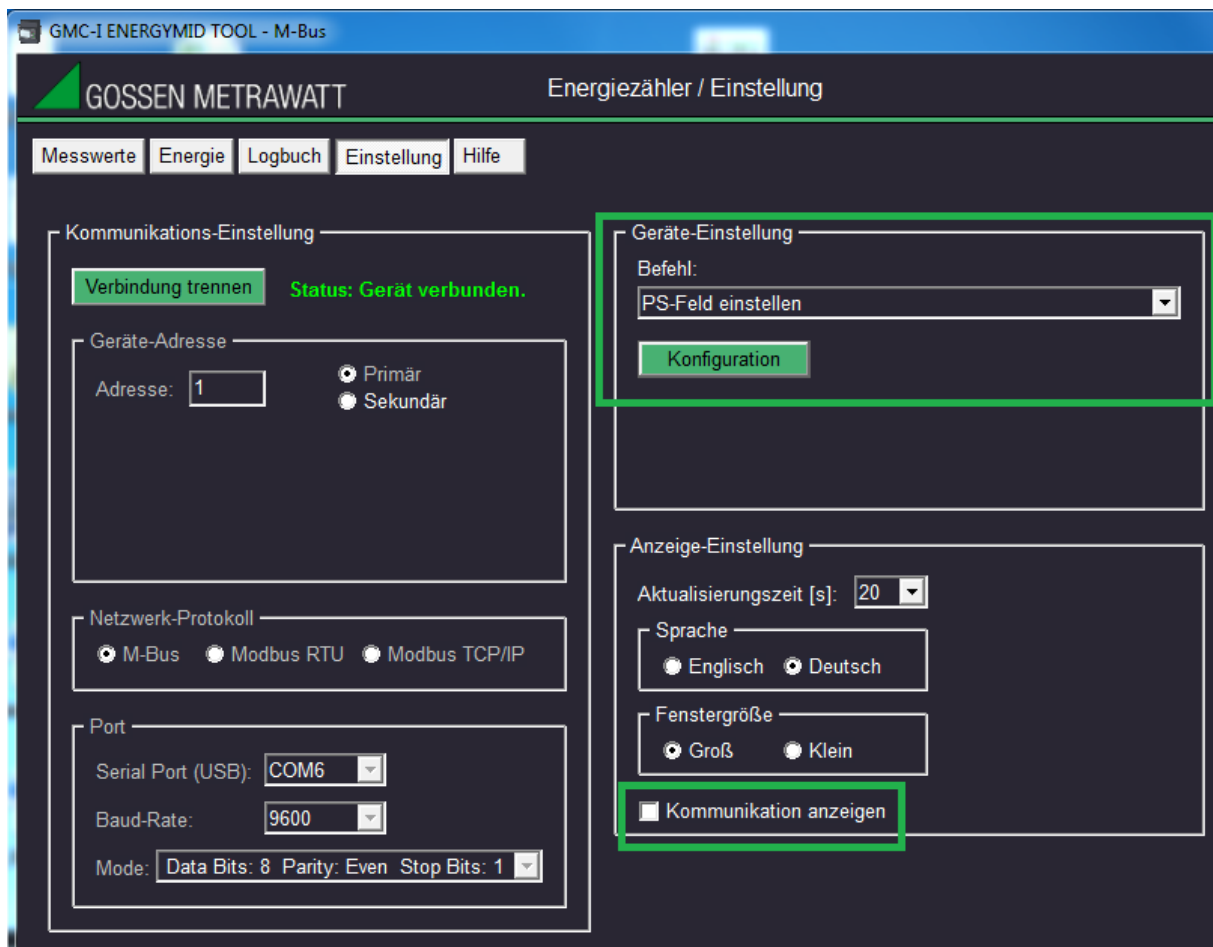

With the help of the tool the protocol can now be configured as desired. The protocol can be adjusted by ticking the desired parameters. The following figure shows the setting for the standard telegram. The settings can be saved in the PC with „Store“.

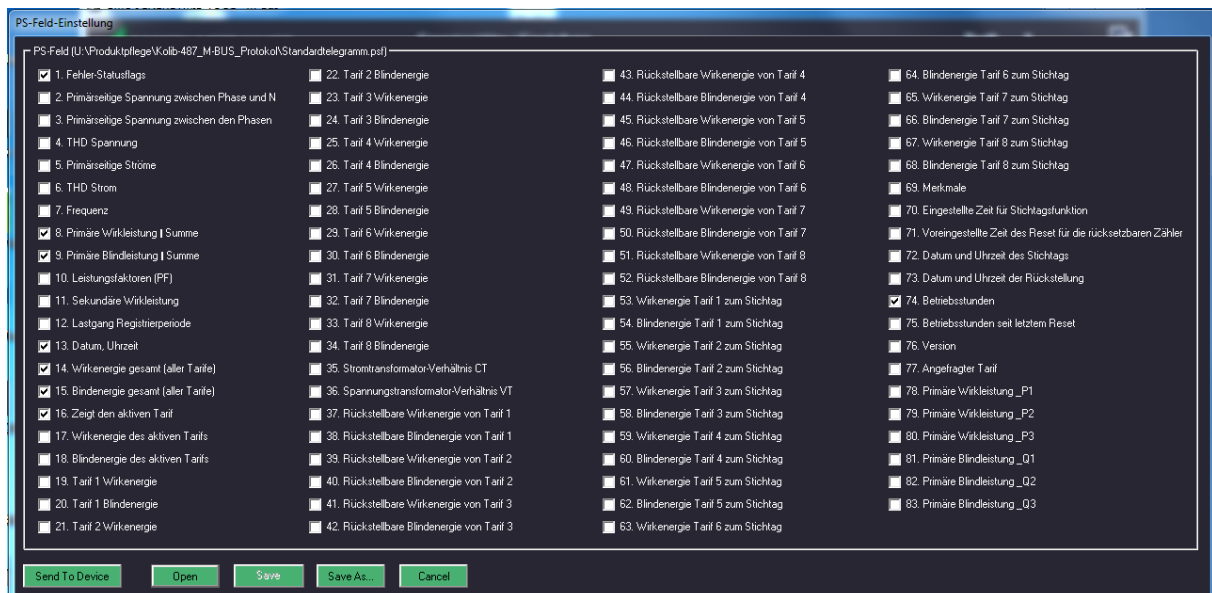

Important note: Only use ENERGMID tool versions V1.17 or higher for meters with M bus firmware from V1.15 onwards.

The ENERGMID tool up to version 1.17 permanently changes the telegram format of the meter for meters with M bus firmware 1.15. In order to remedy this, the telegram format must be reconfigured with a current ENERGMID tool as from V1.17 in accordance with the description given above.

6 Control and Display Functions

Parameter Settings Overview (excerpt from operating instructions 3-349-868-03, supplement including M-Bus parameter settings)

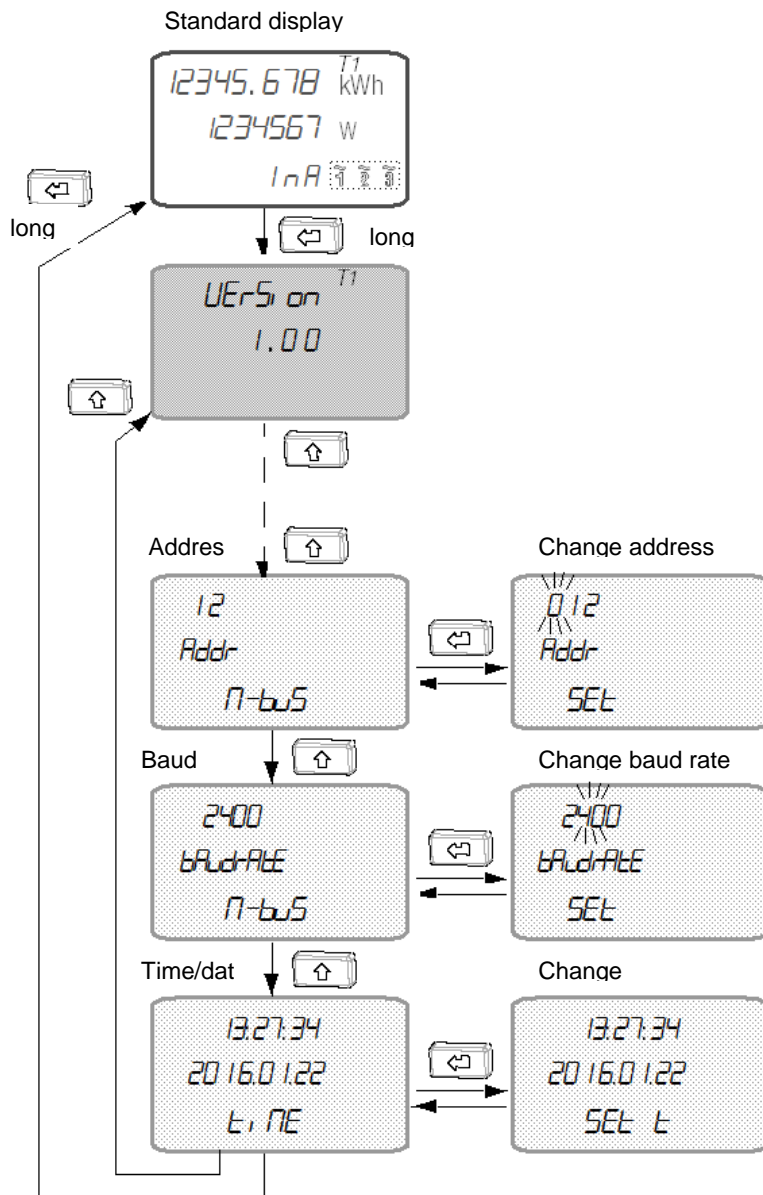

7 Product Support

If required please contact:

GMC-I Messtechnik GmbH

Industrial Product Support Hotline

Phone: +49 911 8602-500

Fax: +49 911 8602-340

e-mail: support.industrie@gossenmetrawatt.com

Edited in Germany • Subject to change without notice • PDF version available on the Internet

 **GOSSEN METRAWATT**
GMC-I Messtechnik GmbH
Südwestpark 15
90449 Nürnberg • Germany

Phone: +49 911 8602-111
Fax +49 911 8602-777
E-Mail info@gossenmetrawatt.com
www.gossenmetrawatt.com